

# E-Lite

Cat. No. EAVE  
 Cat. No. EAVE105  
 Cat. No. EAVEGU  
 Cat. No. EAVE105GU



The E-Lite is a recessed downlight ideal for installation in eaves, soffits, entrance ways, verandahs, carports or covered decks. It can also be used in bathrooms, kitchens or where moisture transfer or decibel rating is a minimum requirement.

This luminaire is machined from a choice of solid aluminium with a UV stable powder coated finish, solid copper or 316 stainless steel with a clear, tempered, flush glass lens and high temperature silicon gaskets. The 316 stainless steel E-Lite is electro-polished to increase corrosion protection.

A 105mm version of the E-Lite is available and has been designed to fit a standard 90mm cut-out with an enlarged canister lip.

A GU10 version of this luminaire is also available for line voltage lamps.

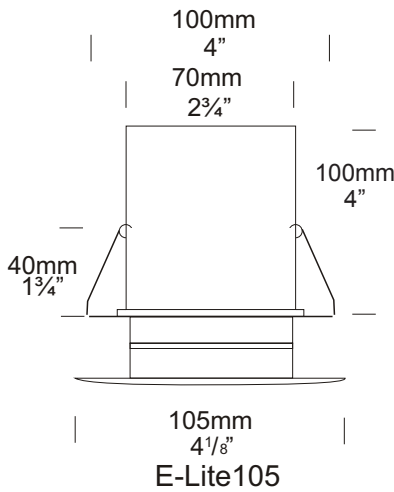
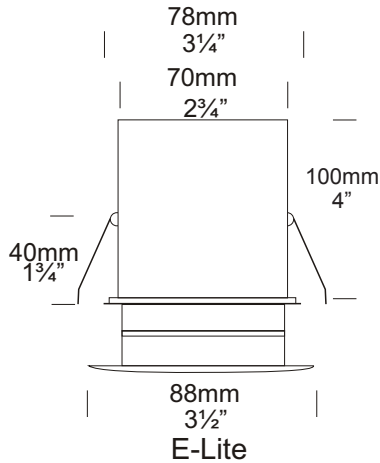

E-Lite

## Ordering Information

Luminaire Type	Material	Accessories
EAVE - E-Lite	BK - Black	LENSSTEPF - Frost Lens
EAVE105 - E-Lite 105mm	BZ - Bronze	GU - GU10 Option
	GN - Green	
	STAR - Silver Star	
	WH - White	
	WB - Birch	
	DG - Dark Grey	
	OG - Olive Green	
	RG - Beige	
	PR - Primrose	
	SS - 316 Stainless Steel	
	COP - Copper	

Ordering Example: EAVE COP - E-Lite in Copper

EAVE105 BK - E-Lite in Black with 105mm flange

EAVEGU COP - E-Lite GU10 in Copper

**HUNZA**™ PURE OUTDOOR LIGHTING

**HUNZA FACTORY**  
 130 Felton Mathew Ave  
 Glen Innes  
 Auckland 1072  
 New Zealand

Ph: 64-9-528 9471  
 Fax: 64-9-528 9361  
 hunza@hunza.co.nz  
 www.hunza.co.nz

**INTERNATIONAL CONTACTS:**  
[www.hunza.co.nz/contacts.php](http://www.hunza.co.nz/contacts.php)

Specifications may change without notice.  
 Manufactured in New Zealand.  
 © 2011 Hunza Holdings Ltd.

Ver 1.4

## Luminaire Construction

CNC machined from:

**Aluminium** body high corrosion resistant 88mm (3½"), or 105mm (4¼") solid aluminium rod with chromate substrate and high UV resistant polyester powder coat.

**Colours** Black, Bronze, Green, Silver Star, White, Birch, Dark Green, Olive Green, Beige, Primrose.

**Copper** body 88mm (3½"), or 105mm (4¼").

**316 Stainless Steel** body 88mm (3½"), or 105mm (4¼"). Electro-polished.

**Canister** 316 Stainless Steel  
**Mounting**

The canister supplied is designed to fit through a 70mm hole and be fixed into position by two spring clips. The E-Lite105 canister has a larger flange (105mm) and has been designed to fill a 90mm hole.

## Features

**Lens:**

10mm (3/8") clear flush fit shatter resistant glass. A clear lens is fitted as standard.

**Lifetime Warranty.**

**Lamp Holders:**

GU5.3 & GU10 - 350°C (662°F) ceramic multi contact lamp holder with 250°C (480°F) teflon cables.

**Accessories:**

Frost Lens (Cat. LENSSTEPF). GU10 Option (Cat. GU10).

*The stainless steel E-Lite is electro-polished, this finish increases the protection against corrosion by up to 33%.*

## Standards

**IPX5, NON-UL**

NZIEP 54 = CA, SCB 100mm  
HBX 75mm, REC 135mm  
DB = RW30

**Weight**

E-Lite Alum .30 kg (11oz)  
Cop .80 kg (1lb 12oz)  
SS .75 kg (1lb 10oz)

E-Lite105 Alum .40 kg (14oz)  
Cop .95 kg (2lb 2oz)  
SS .90 kg (2lb)

**Power Supply**

HUNZA™ H20, H40 or H50  
Transformer: not included.

**Lamp Type**

Suitable for use with Halogen  
MR16 GU5.3 50 watt lamp max.  
GU10 - GU10 25 or 35 watt lamp max.

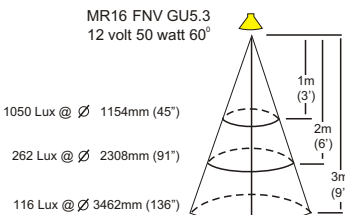
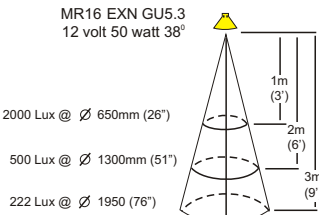
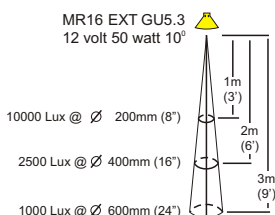
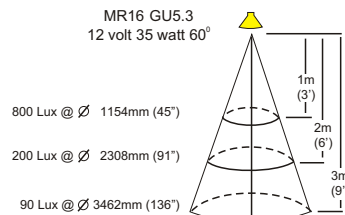
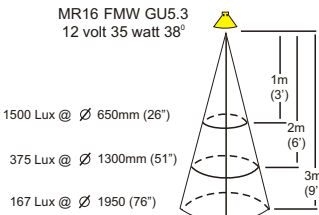
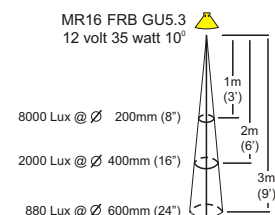
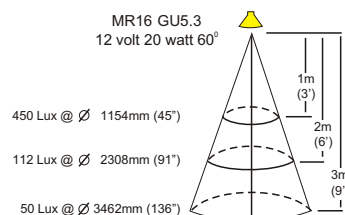
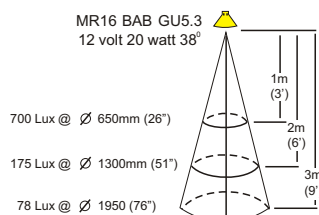
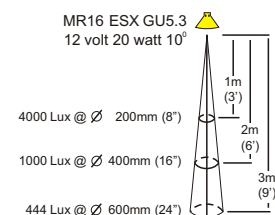

**HUNZA™** PURE  
OUTDOOR  
LIGHTING

**HUNZA FACTORY**  
130 Felton Mathew Ave  
Glen Innes  
Auckland 1072  
New Zealand

**Ph: 64-9-528 9471**  
**Fax: 64-9-528 9361**  
hunza@hunza.co.nz  
www.hunza.co.nz

**INTERNATIONAL CONTACTS:**  
www.hunza.co.nz/contacts.php

Specifications may change without notice.  
Manufactured in New Zealand.  
© 2011 Hunza Holdings Ltd.

Ver 1.4